

HRA | DOUBLE ACTING HIGH TONNAGE ALUMINIUM CYLINDERS



Capacities from 32 to 110 tonnes

Stroke lengths from 51 to 305 mm

Working pressure 700 bar

- ▶ Lightweight aluminium cylinders for applications where weight and portability are of prime importance
- ▶ Double acting design offers higher work output with improved performance and efficiency
- ▶ Hard anodised piston rod and cylinder for corrosion resistance and increased durability
- ▶ Handles fitted as standard on models 50 tonne upwards
- ▶ Low friction bearing surfaces
- ▶ Anti-extrusion seals for improved performance at high pressures
- ▶ Steel base plate fitted as standard on models
- ▶ Pressure relief valve on annulus side
- ▶ Optional piston rod saddles listed on pages 24 and 25

*see pages 24 and 25
Note: Models from 50 to 110 tonnes feature a handle.

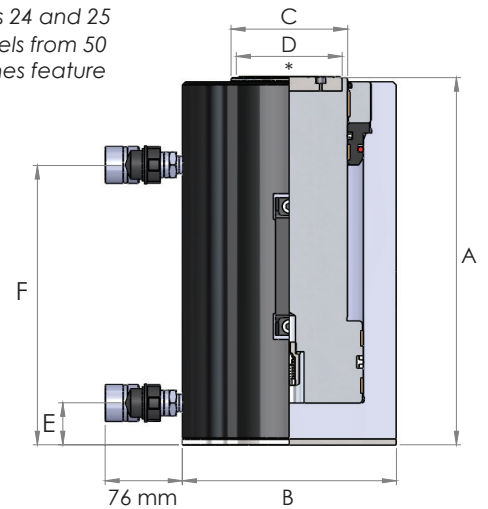

Model number	Capacity (tonnes)	Stroke (mm)	Oil capacity (cm ³)	Cylinder eff. area (cm ²)	Weight (kg)	Dimensions (mm)					
						A	B	C	D	E	F
HRA302	32	51	225.3	44.2	5	204	105	60	50	25	136
HRA306	32	152	671.5	44.2	7	305	105	60	50	25	237
HRA3012	32	305	1347.5	44.2	10	458	105	60	50	25	390
HRA502	51	51	361.5	70.9	10	221	135	79	70	30	141
HRA506	51	152	1077.4	70.9	13	322	135	79	70	30	242
HRA5012	51	305	2161.9	70.9	19	475	135	79	70	30	395
HRA1002	110	51	785.1	153.9	22	258	202	110	100	41	172
HRA1006	110	152	2339.9	153.9	29	359	202	110	100	41	273
HRA10012	110	305	4695.1	153.9	39	512	202	110	100	41	426